

This document includes information on
Transmission Oil Testing.

#1796A
Page 1 of 9

SUBJECT: Oil Analysis Test Recommendations

AFFECTED SERIAL NUMBERS: All Allison Commercial Transmissions and Torque Converters

Introduction:

Oil analysis plays an essential role in monitoring and understanding the general condition of the transmission and transmission fluid/filter system. This document provides information on recommended oil analysis tests and procedures which provide data necessary to assess the transmission and transmission fluid/filter system. These tests and test data are available from most qualified independent oil analysis laboratories.

Oil Analysis Test Recommendations:

The following is the minimum series of tests required to properly monitor the condition of the transmission and transmission fluid/filter system.

- Viscosity (cSt) at 100°C (ASTM D445)
- Viscosity (cSt) at 40°C (ASTM D445)
- TAN (Total Acid Number) (ASTM D664)
- Non-metal Contaminants: Fuel (%vol), Soot (%wt), Water (%vol), Ethylene Glycol (%vol)
- Additive and Contaminant Metals (ppm): Ba, B, Ca, Mg, P, Si, Na, Zn
- Wear Metals (ppm): Fe, Cu, Pb, Al
- Particle Counts (particles/ml) at >5, >10, >15, >20, >30, and 40 microns

ppm = parts per million cSt = centiStokes ml = milliliter

Refer to oil sampling procedure on how to monitor wear metals. Maximum limits for wear metals are not provided due to the multiple variables that affect concentration.

It is vital that all personnel assigned to transmission and transmission fluid/filter system maintenance understand the importance of proper sampling techniques and records keeping in maintaining a quality oil analysis program.

SG/mmww

Allison Transmission, Inc.
Indianapolis, Indiana 46206-0894

Copyright 2007 Allison Transmission, Inc. All Rights Reserved.

OIL SAMPLING PROCEDURE

Installation of Quick Draw Valve

The most uniform samples are obtained when an oil valve probe is installed in an oil galley with constantly circulating fluid. The probe available from the ATD selected oil analysis laboratory is a **Quick Draw valve** and is available in 1/4 inch or 1/8 inch NPT in stainless steel or brass or 7/16 inch or 9/16 inch SAE straight-thread "O"-ring fitting in brass only. These may be purchased directly from:

Polaris Laboratories, LLC
146 South Park Blvd
Greenwood, IN 46143
Telephone (317) 808-3750 or toll-free (888) 456-0120

Physical dimensions of Quick Draw valves are shown on Page 5. For on-highway transmissions, refer to Pages 6, 7, or 8 for recommended placement of Quick Draw valve. For 5/6/8/9000 Series transmissions, refer to appropriate Service Manual for location of main pressure tap. **NOTE:** It may be necessary to tap into the cooler line fittings to provide accessibility. Refer to Table 1 for Quick Draw valve torque values. An optional remote provision for the Quick Draw valve is depicted on Page 9.

Table 1.

Model	Torque Values	
AT/MT/HT Series	5.4–6.8 N·m	(4–5 lb ft)
MD/HD Product Line 1000/2000/2400 Series	10–13 N·m	(7–10 lb ft)
5/6/8/9000 Series:		
NPT	5.4–6.8 N·m	(4–5 lb ft)
Straight-Thread	10–13 N·m	(7–10 lb ft)

CAUTION: *Vehicle operating environment must be considered if permanent installation of Quick Draw valve or remote oil sample hose is desired. Vehicles that operate off-road or have low ground clearance pose a greater risk of road/debris impact to the Quick Draw valve and subsequent transmission damage.*

Fluid Sampling:

Proper fluid sampling consists of the following procedure:

- The first sample data point must be from an unused, new fluid sample to establish initial levels for which subsequent used oil samples will be compared.
- Second sample data points of used oil samples should be taken per recommendations in Chart 1.
- Subsequent sample data points of used oil samples should be taken per recommendations in Chart 2. Subsequent draw of used oil samples will continue until the fluid exceeds any of the limits contained in Tables 2 and 3.

Once a fluid/filter change is performed, the next sample data point should occur per the recommendations in Chart 1. Subsequent sample data points should again be taken per the recommendations in Chart 2 until the fluid exceeds any of the limits contained in Tables 2 and 3.

Extraction of Fluid Sample:

To obtain a representative fluid sample, the following conditions must exist at the time the fluid sample is taken:

1. Transmission sump temperature above 60°C (140°F) (If transmission temperature is not available, engine must be at operating temperature).
2. Engine at idle, transmission in Neutral.
3. Vehicle wheels chocked and vehicle brakes applied.

Before attaching collection bottle, install needle/cap assembly into Quick Draw valve to allow a **minimum of three fluid ounces** to purge into a container. This removes prior oil/debris trapped in Quick Draw valve and/or remote oil sample hose. Once Quick Draw valve and/or remote oil sample hose has been purged, install collection bottle to the needle/cap assembly and fill collection bottle approximately 3/4 full.

Discard the used tube and probe properly. **Do not reuse.**

Submission of Oil Sample:

Fill out the label completely with the transmission serial number, hour meter/mileage reading, sample date, and hours/miles accumulated on the oil. Indicate whether or not the oil was changed after the sample was taken. Attach the label to the bottle, package carefully using materials supplied by the lab, and send it immediately.

Presence of glycol contamination is analyzed. Cost of oil analysis is included in the cost of the oil analysis kit P/N 29537805.

FLUID ANALYSIS

Transmission protection and fluid change intervals can be optimized by monitoring fluid viscosity and oxidation. Fluid degradation is monitored by testing for viscosity and total acid number (TAN). Fluid oxidation limits are shown in Table 2.

Table 2.

Condition	Limit
Viscosity	+/- 25% Change From New Fluid
Total Acid Number	+3.0 Change From New Fluid

Since limits are referenced from an unused oil sample, when beginning fluid analysis or repurchasing bulk oil stock, i.e. 55 gallon drum and larger, collect a new, unused oil sample and submit for analysis. Viscosity and TAN values measured from unused sample create the baseline that future used oil sample will be measured against.

Monitoring Contaminant Levels

The presence of contaminants in the transmission fluid is detrimental and indicates a fluid change is necessary. Contaminant limits are shown in Table 3.

Table 3.

Contaminant	Limit
Water	0.2% Maximum
Glycol	No Trace Allowed
Alien Fluids*	If Detected, Change Transmission Fluid
* Any fluid not listed on the Allison C4 Approved Fluids List or licensed by General Motors as a DEXRON®-III fluid. NOTE: The Allison-approved C4 fluids list can be found at www.allisontransmission.com	

Monitoring Wear:

Absolute maximum values are not applied to wear metals of an automatic transmission due to the many variables present that affect concentration limits. Wear metal analysis results must be evaluated using a trendline approach. A trendline approach plots the concentration level of each wear metal over a period of time. A line of best fit drawn through the plotted points is considered a trendline. A minimum of 4 data points for each wear metal is required to establish a trendline.

Concern should only occur when significant deviations in the established trendline are present. While trendline analysis on wear metals can prove informative and useful, a transmission removal decision should not be based solely upon the analysis. The results should be used in conjunction with other inspection procedures such as a functional check, road test, oil sump/internal filter inspection, or elevated particle counts. A removal based solely on wear metal analysis may result in an unnecessary teardown. Transmission removal should occur only if the additional investigation warrants it.

If there is ever any doubt on the significance of any fluid analysis reports, or a need to react to a condition, assistance should be sought through a servicing outlet or Allison regional office.

Chart 1. Recommended Initial Fluid Sample Draw

Model	Vocation	Non-TranSynd™	TranSynd™
WT/AT/MT	Severe	5000 miles (8000 km) 200 hours	25,000 miles (40 000 km) 1000 hours
	General	15,000 miles (24 000 km) 600 hours	50,000 miles (80 000 km) 2000 hours
HT	Severe	25,000 miles (40 000 km) 600 hours	25,000 miles (40 000 km) 600 hours
	General	25,000 miles (40 000 km) 600 hours	50,000 miles (80 000 km) 1200 hours
1000/2000/2400	Severe	15,000 miles (24 000 km) 600 hours	25,000 miles (40 000 km) 1000 hours
	General	25,000 miles (40 000 km) 1000 hours	50,000 miles (80 000 km) 2000 hours
5/6/8/9000	N/A	250 hours	250 hours

Severe Vocation: All Retarders, On/Off Highway, Refuse, Transit, and Intercity Coach with duty cycle greater than one (1) stop per mile.

General Vocation: Intercity Coach with duty cycle less than or equal to one (1) stop per mile and all other vocations.

Chart 2. Recommended Subsequent Fluid Sample Rates

Model	Non-TranSynd™	TranSynd™
WT/AT/MT/HT 1000/2000/2400	5000 miles (8000 km) 250 hours	10,000 miles (16 000 km) 500 hours
5/6/8/9000	250 hours	250 hours

NOTE: Fluid sample frequency may need to be modified due to analysis results. For example, if analysis indicates fluid viscosity has changed by 25 percent, customer should sample at a greater frequency than recommended in Chart 2. Local conditions, severity of operation or duty cycle may require more or less frequent fluid sample intervals that differ from the published recommended fluid sample intervals of Allison Transmission.

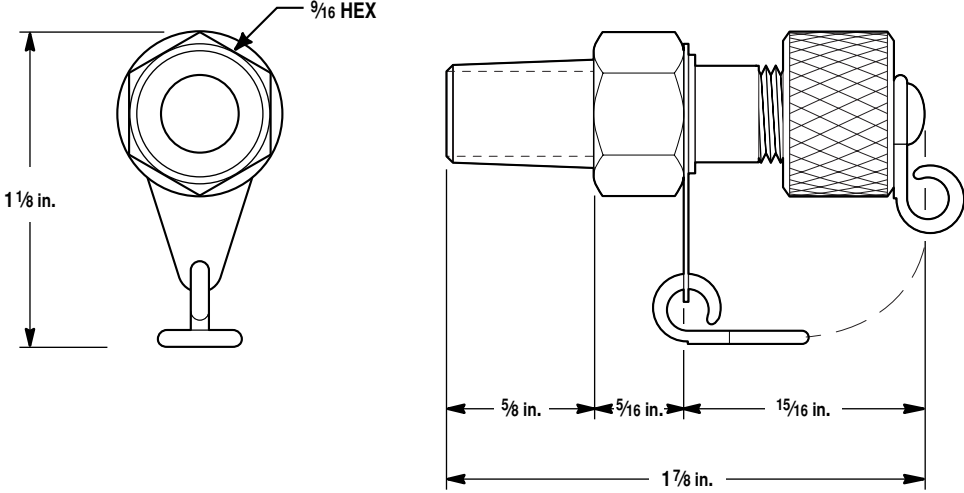

NPT QUICK DRAW VALVE

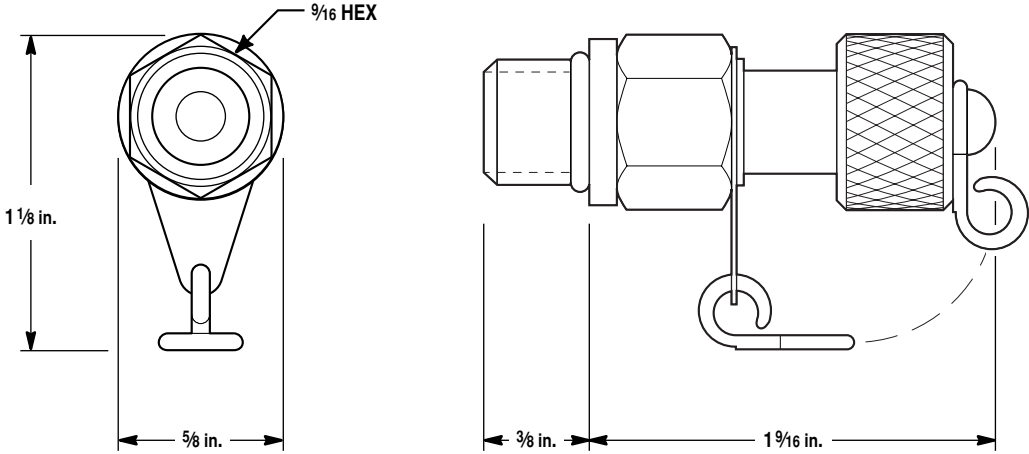

SAE STRAIGHT THREAD QUICK DRAW VALVE

AT 500/1500 SERIES

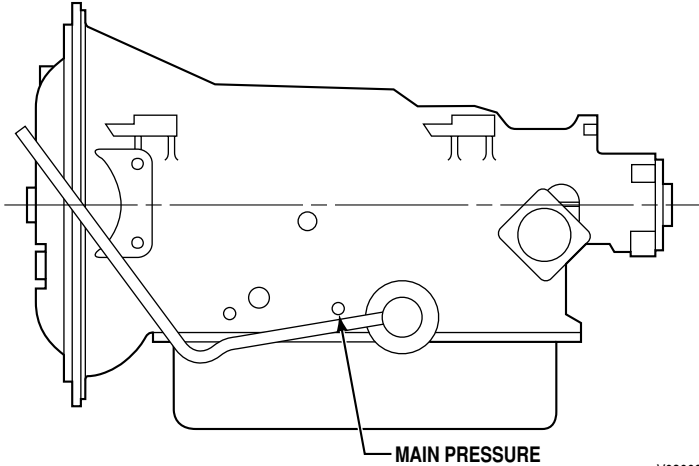

V03009.01

MT 600 SERIES

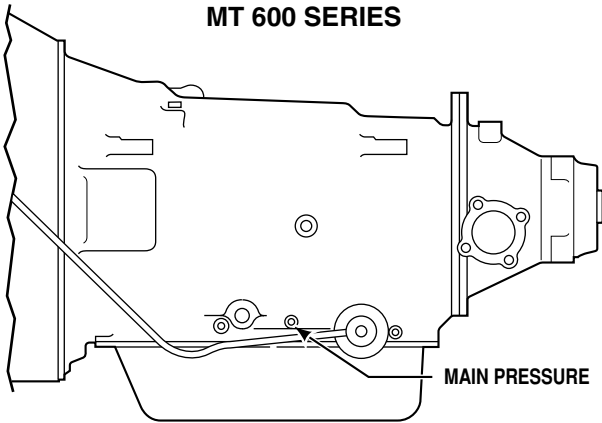

V03248.01

1000/2000/2400 SERIES

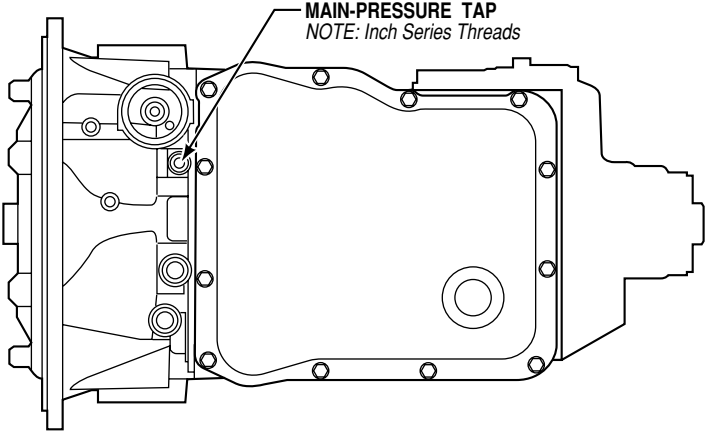

V05742.03

HT 700 SERIES

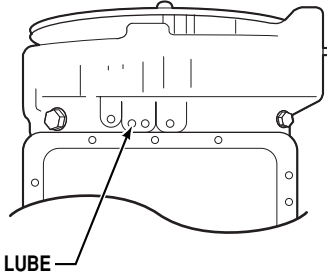

V07050

**MD/B 300/B 400
3000MH**

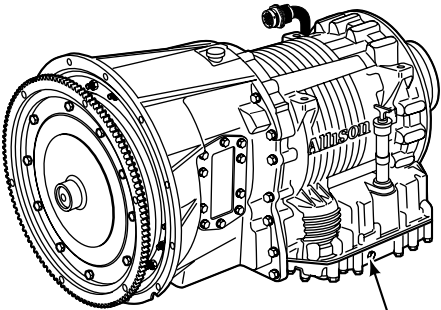

MAIN-PRESSURE TAP
NOTE: Inch Series Threads

**HD/B 500
4000MH**

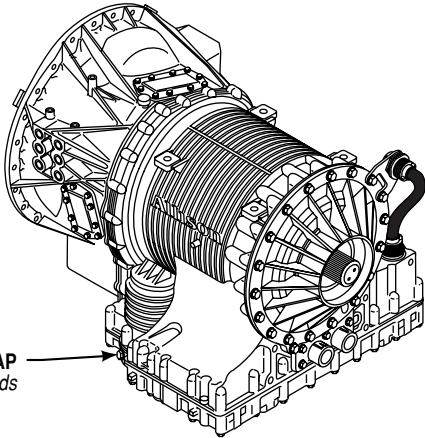

MAIN-PRESSURE TAP
NOTE: Inch Series Threads

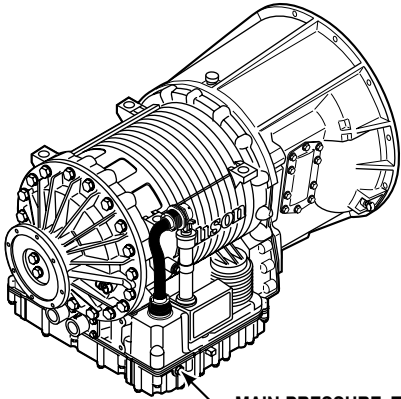

MAIN-PRESSURE TAP
NOTE: Inch Series Threads

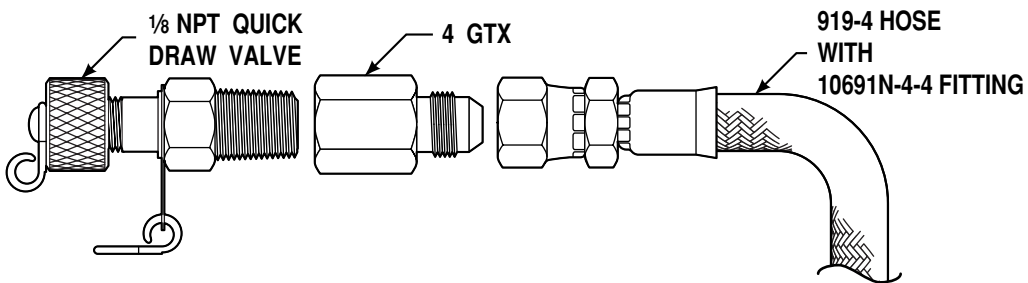

- Recommended maximum length of hose is 3 meters (10 feet).
- Hose must not contact or have potential to contact sharp or abrading surfaces.
- Hose must be routed carefully to avoid sharp bends, kinking, pinching, cutting, or rubbing.
- The hose must not be under tension between fixed points. This is especially relevant in view of the movement of the powerpack within the frame. "Tension" is considered to be any strain greater than the hose itself.
- Hose must be a minimum of 203 mm (8 inch) from radiant heat sources. Heat sources are defined as engine exhaust systems and manifolds.
- Hose should be secured every 400 mm (16 inch). Clamps must be properly sized to the OD of the hose to avoid crushing or deforming the hose.
- Torque hydraulic fittings to manufacturer's specifications.

Refer To
Pages 6, 7, and 8
for placement of
fitting.

Refer to Table 1 for
adapter to transmission
torque value.

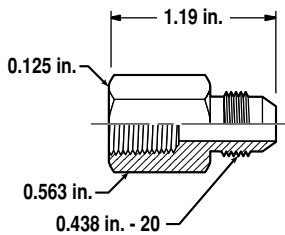
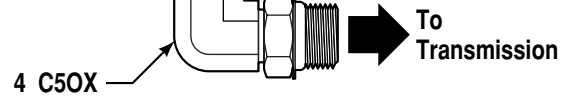

4 GTX

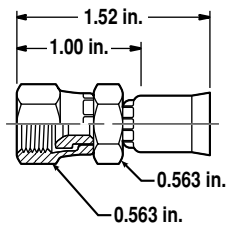

10691N-4-4
FITTING

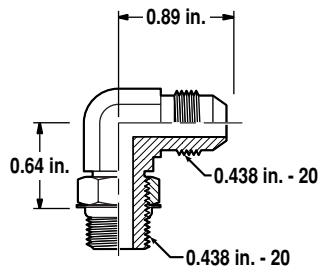

4 C50X
(MD/HD PRODUCT LINE
1000/2000/2400 SERIES
5/6/8/9000 SERIES)

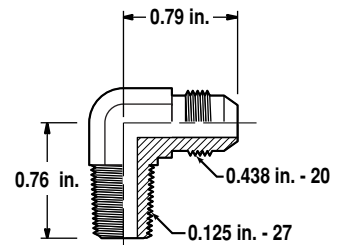

4 CTX
(AT/MT/HT PRODUCT LINE
5/6/8/9000 SERIES)

Components listed are available from Parker Hannifin Corp. with the exception of the quick draw valve. Hydraulic components other than Parker are acceptable providing they are equivalent or exceed specifications of listed Parker hydraulic components.